

PNEUMATIC ACTUATED PVC BALL VALVE



Pneumatic Actuated PVC Ball Valve

PVC ball valves can be controlled by pneumatic and electric actuator. PVC ball valves are suitable for water, acid and chemical fluid types. There are flanged, gear and slip types of connections.

Benefits

1. Suitable for drinking water, acid and chemical fluids standards
2. Lower torque requirement for on-off
3. %100 running test at factory
4. Electric actuators suitability
5. Easy installation, de-installation possibilities

Applications

1. Material : PVC
2. Size: 1/2" – 2 1/2"
3. Connection: threaded – flanged- slip types
4. Working Pressure: 0-16 bar
5. Ambient Temperature: 0°C - 50°C
6. Actuator Pressure: 4 - 8 bar
7. Standard: ISO 5211

Features

8. It controls the water in the system. There are options with electric and pneumatic actuator.
9. Its acid resistance is amplified with its private sphere seal assembly. PVC and EPDM is used for control of the system to fit every kind of acid.
10. VITON seals use for the application where EPDM is not suitable. It has a high acid resistance.

Materials

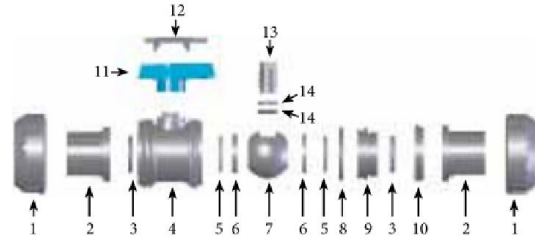

1. **Union Nut:** PVC-PP-HDPE
2. **End Connector:** PVC-PP-HDPE
3. **Body Seal:** EPDM-Viton
4. **Body:** PVC-PP-HDPE
5. **Backing Seal:** EPDM-Viton
6. **Ball Seal:** PE-PP-Teflon
7. **Ball:** PVC-PP-HDPE
8. **Carrier O-Ring:** EPDM-Viton
9. **Carrier Ball:** PVC-PP-HDPE
10. **Seat Carrier:** PVC-PP-HDPE
11. **Valve Handle:** ABS
12. **Handle Cover:** PVC
13. **Step:** PVC-PP-HDPE
14. **Step Seal:** EPDM- Viton

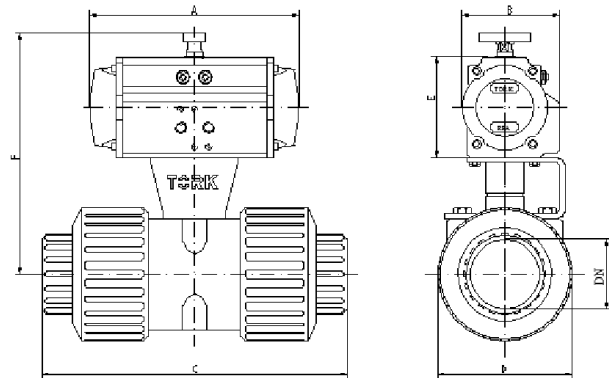
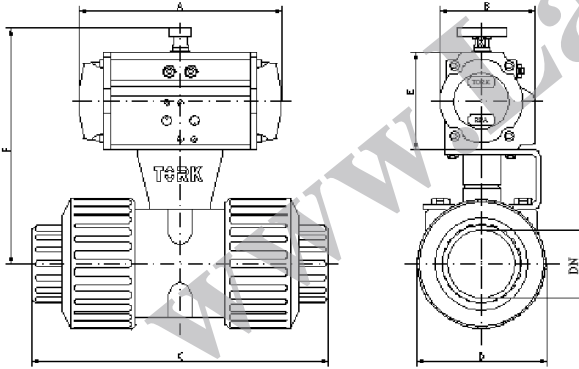

ACT. TYPE	DN	A	B	C	D	E	F
DA 40	15	139,2	70,6	114	45	70	150,5
DA 40	20	139,2	70,6	135	55	70	160
DA 40	25	139,2	70,6	149	66	70	169
DA 40	32	139,2	70,6	168	82	70	178
DA 40	40	139,2	70,6	175	98	70	197
DA 60	50	178	82,5	208	120	85	223

ACT. TYPE	DN	A	B	C	D	E	F
SR 40	15	139,2	70,6	114	45	70	150,5
SR 40	20	139,2	70,6	135	55	70	160
SR 40	25	139,2	70,6	149	66	70	169
SR 60	32	139,2	70,6	168	82	70	193
SR 60	40	139,2	70,6	175	98	70	212
SR 80	50	178	82,5	208	120	85	255

Double Acting Pneumatic Actuated PVC Ball Valve

Spring Return Pneumatic Actuated PVC Ball Valve